

GVMAX

Self-Regulating Vacuum Pumps (Pneumatic Vacuum and Blow-off Control)

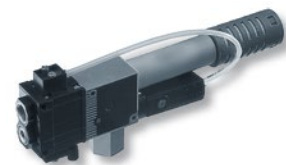

Industry-specific applications



The communication between both elements, pneumatic vacuum switch and gripping valve control, enables the consumption of compressed air to be regulated and in particular significantly reduced. This range of vacuum pumps is strongly recommended for gripping airtight objects, clamping, and for medium or long cycles in explosive environments. Pneumatically controllable blow-off is integrated for release.

Note: The volume of the piping must not exceed 10 liters. For higher volumes, please consult us.

Materials

PA 6-6 15% FV, POM, PC 15% FV, brass, aluminum, NBR.

Safety

The GVMAX P1 has two non-return valve functions installed as standard which enables it to maintain the vacuum within the circuit if the pneumatic power is interrupted. This function guarantees maximum safety conditions for operators during handling.

Characteristics

model	Ø nozzle (mm)	max. vacuum (%)			air drawn in (SCFM)			L2 (mm)		⊞ (g)
		X	T	N	X	T	N	S	K ⁽¹⁾	
GVMAX P1	2.5	50	75	90	12.71	8.48	7.06	60	121	440

(1) delivered as standard on version X.

Evacuation Time in Seconds per Liter

% vacuum versions	Ø nozzle (mm)	10			20			30			35			40			45			50			60		70		80		85	
		X	T	N	X	T	N	X	T	N	X	X	T	N	X	T	N	T	N	T	N	T	N	N	N	N	N			
GVMAX P1	2.5	0.02	0.03	0.03	0.04	0.06	0.07	0.08	0.10	0.11	0.01	0.14	0.14	0.16	0.19	0.21	0.22	0.30	0.30	0.50	0.41	0.60	0.60	0.77						

Operating Principle

When the selected vacuum level is reached, the compressed air supply stops. This interruption does not have any effect on the operation in progress as the no-return valve maintains the vacuum and thus the grip. The vacuum switch continually analyzes the vacuum requirements. As soon as the minimum threshold is reached, it activates the vacuum generation valve. The chosen level of vacuum is immediately re-established. See page 8/39.

Specifications

Supply	Non-lubricated filtered air, 2 to 6 bar, optimum at 4 bar
Temperature	32 to 140 °F
Vacuum switch	PSE100PKNO
Pressure at the vacuum switch	Equal to or greater than vacuum pumps supply pressure
Hysteresis	100 mbar max.

Curves: see page 8/43

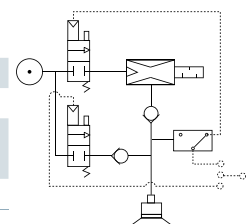

Note: to ensure optimum operation, we advise you to ensure the vacuum network is airtight. For this purpose we recommend using NVS vacuum feeders and screwed vacuum fittings with O-rings (RDV, RCOV).

Dimensions

- (1) 5.5 bar compressed air input
- (2) Fast 2.7x4 blow-off control
- (3) G1/2"-F Gas Exhaust
- (4) Regulation threshold adjustment
- (5) PSE100PKNO vacuum switch
- (6) Hollow shaft for vacuum control vacuum switch pressurization
- (7) G1/4"-F

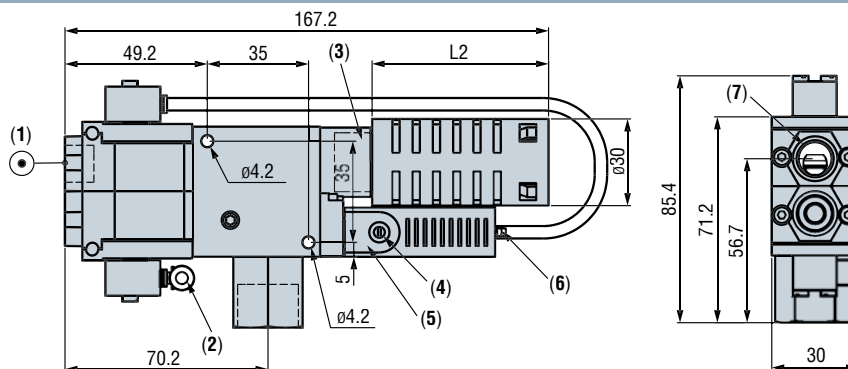

8 GVMAX



For all orders, please specify:
Model + Characteristic + Silencer + C.A. fitting + Pilot
Example: GVMAXNK14P1

1: Model	2: Characteristic	3: Silencer		4: C.A. fitting	5: Pilot	
GVMAX	X	50 % vacuum	-	Without silencer	14 G1/4"-F	P1
	T	75 % vacuum	S	Diffuser		
	N	90 % vacuum	K	Through-type		